

LATE 19TH- AND EARLY 20TH-CENTURY MANUFACTURE OF DRAWN GLASS TUBING FOR GLASS BEADS

Lester A. Ross

Late 19th- and early 20th-century archaeological sites often contain machine-made drawn glass beads with unique shapes and perforations. Little information exists documenting when these beads were initially manufactured. Through an examination of hundreds of U.S. patents, it appears that the mechanized production of drawn beads could have occurred as early as the late 19th-century, but more likely, they were not mass produced until the end of World War I, after the invention of the Danner process for mechanically drawing glass tubing. Machine-made drawn beads with multiple sides and/or shaped perforations also appear to have been produced by the late-19th century, but again, mass production probably did not occur until after the end of World War I.

INTRODUCTION

Glass tubing used for the production of drawn beads destined for trade and sale to Native Americans was manufactured by a centuries-old process of pulling a hollow gather of molten glass into a tube (Anonymous 1881; Bussolin 1847; Carroll 1917; Francis 1988; Karklins with Adams 1990; Kidd 1979; Neuwirth 1994:130-149, 201-213; Sprague 1985:87-92). With the advent of the Industrial Revolution in the late 18th century, new equipment and techniques began being patented to speed the process and move the industry from a labor- to capital-intensive market, with the principal goal of reducing the costs of production. From known primary historical documents and existing secondary historical accounts, it is unclear if and when many of these newer methods were adopted and became common. In order to begin the research process of clarifying this transition, it would be helpful to identify dated sources to establish *terminus post quem* (i.e., post-), *terminus ad quem* (i.e., pre-), and *terminus a quo* (i.e., post- to pre-) dates for new inventions, processes, and products. To this end, three hypotheses are offered and documented with the intention of having additional historical, ethnographical, and archaeological research evaluate and revise them.

Research for this article is based in part on a search of United States patent records using current classification numbers pertaining to specific products, processes, and apparatus. Online searches of the U.S. Patent Office web site for keywords can only be done for records later than 1975. Searching by classification numbers, however, it is possible to search all records from 1790. The initial search examined all patents under the current classification number of CCL/65, Glass Manufacturing. For glass tubing and cylinders, patents listed under CCL/65 were searched. From these primary searches, related classification numbers were identified and searched. Using this approach, thousands of patents were examined, locating over 250 patents for the manufacture of glass tubing and cylinders. Occasionally, patent records were filed by classification numbers that did not reflect the true nature of the patent, so searching by classification numbers probably failed to locate all relevant patents. Based upon secondary historical sources, however, it appears that at least the primary patents for glass tubing have been located.

During the late 19th century, there were hundreds of patents for the manufacture of glass articles by machine. Most notably were tools, equipment, and machines for the manufacture of:

Pressed glass articles, including:

- Ornamental glassware
- Telegraph and electrical insulators

Blown and molded glass articles, including:

- Lamp chimneys
- Bottles and jars
- Incandescent electric lamps

Molded glass articles, including:

- Buttons
- Imitation gems
- Pipes

Rolled glass articles, including:

- Window sheet glass
- Wired sheet glass

Drawn glass articles, including:

- Window sheet and cylinder glass
- Pipes
- Water gauge tubing
- Clinical thermometers

Of these processes, only the techniques for the manufacture of drawn glass tubing, with or without shaped perforations, which might have been used for the production of general purpose tubing, were examined. Associated patents for specialized parts of glass drawing apparatus were not examined in detail, unless they pertained to the manufacture of unique perforations and exterior shapes other than circular. Also not considered were various patents for the alteration of glass tubing for specialized functions. For example:

- U.S. Patent Nos. 883,875 (April 7, 1908) and 885,039 (April 21, 1908) for flanging mount tubes used inside incandescent lamps.
- U.S. Patent No. 946,179 (January 11, 1910) for the creation of microscopic glass tubing commonly referred to as fiber or spun glass.
- U.S. Patent No. 982,212 (January 17, 1911) for the shaping of pre-existing tube ends.
- U.S. Patent No. 1,024,116 (April 23, 1912) for the manufacture of vials from tubing.

Because of its title and possible confusion with ornamental beadmaking, the following patent is mentioned but not included in the following sections:

U.S. Patent No. 1,117,060 (November 10, 1914) granted to Johann Kremenezky and Josef Jelliner of Vienna, Austria-Hungary, Assignors to the firm of Johann Kremenezky for a machine for producing beads on glass rods.

In their description, Kremenezky and Jelliner state that “this invention relates to a machine for producing beads on glass rods, more particularly on such glass rods as are used in the supporting frames for metal filaments of electric incandescent lamps....” From their descriptions and drawings, the appearance of the final product is unclear, but the “beads” may just consist of spheroidal upsets on one end of a short glass rod that can be inserted into the base of an electric light bulb.

MANUFACTURE OF GLASS TUBING WITH SHAPED PERFORATIONS

Drawn beads with shaped perforations have been recognized at several late 19th- and early 20th-century archaeological sites:

1. An 1850s to early 1860s archaeological context at American Fur Company Fort Union, South Dakota, produced a single monochrome, transparent green, six-sided, short drawn bead with chopped ends and two rows of ground facets with a hexagonal perforation (Ross 1999: Variety 278). This is a relatively thin-walled bead, and the sides of the perforation align with the exterior sides. This indicates that the perforation shape was produced when the sides of the bead were formed, probably an accidental coincidence.

2. An 1873-1905 archaeological context at the Shepherd ranch house site, Inyo County, California, yielded a single monochrome, opaque white, short cylindrical, undecorated, hot tumbled, drawn bead with a triangular perforation (Fig. 1 a)(Ross 2004: Variety 34). Possibly an aberrant specimen of another bead variety at this site (Variety 6), although the shaped perforation appears deliberate and does not correspond with the shape of the bead, nor does it appear to have been created by flattening when the original tubing cooled.

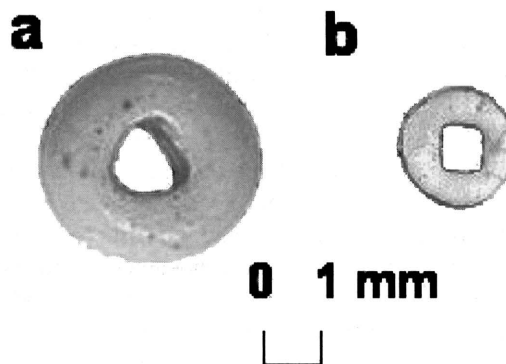

Figure 1. Examples of hot-tumbled, drawn glass beads with shaped perforations from archaeological sites: a) opaque white, short cylindrical with a triangular perforation from the Shepherd ranch house site, Inyo County, California, 1873-1905 (Ross 2004: Variety 34; enhanced photo by L. Ross); b) transparent light gray with an opaque light red enamel-coated square perforation from the Hudson’s Bay Company York Factory site, Manitoba, Canada, ca. 1875-1950 context (Karklins and Adams n.d.), Variety 120; enhanced photo by R. Chan, Parks Canada).

3. At a ca. 1888-1921 site in The Dalles, Oregon, “a sample of ‘seed’ beads with square and hexagonal holes were collected by members of the Oregon Archaeological Society” (Hoffman and Ross 1974:74). Personal examination of these beads indicated that the perforations were intentionally manufactured resulting in shapes with sharp and well defined sides and corners.

4. At Hudson’s Bay Company York Factory, Manitoba, Canada, where four varieties of monochrome, short cylindrical, undecorated, rounded drawn beads with square perforations (York Factory varieties 116a, 119, 120 and 121; Karklins and Adams n.d.) were found in contexts dating to the late 19th and first half of the 20th century:

- Variety 116a (n = 1), transparent pink
- Variety 119 (n = 26), opaque white
- Variety 120 (n = 5), transparent light gray with an opaque light red enamel-coated perforation (Fig. 1 b)
- Variety 121 (n = 1), transparent bright chartreuse with an opaque metallic silver-coated perforation

Beads with square perforations will probably be the most commonly observed variety, but other shapes can also be anticipated. For purposes of dating archaeological contexts, it would be helpful to know when beads with shaped perforations initially appeared.

In her book on beads from central Europe, Waltraud Neuwirth (1994:145) noted that “in the beginning the perforations had round cross-sections, later they could also have square, triangular or wide (for stringing on ribbons) shapes.” Neuwirth, however, offers no information regarding the date or country where this transition initially occurred. It is further stated that: “The cross-sections of tubes and canes were also round in the beginning; the invention of square drawn glass is placed in connection with the Tiefenbach glasshouse in 1803” (Neuwirth 1994:145 citing Vienna [Wien] 1845, Lloyd 1845). One might conclude from a quick reading of this passage that the date of 1803 refers to the shaping of perforations. The cross-sections referenced pertain to the exteriors of tubing and canes, however, not the perforations of tubing.

Presently, the earliest primary historic document yet identified that discusses shaped perforations is the 1926 patent by Richard Hirsch (Table 1). Other inventors patented processes for imparting various shapes to the exterior of tubing as well as their perforations, but all were for tubing used for limited and specialized applications (Table 1).

It is doubtful that the 1906 date for Raspillaire’s patent actually represents the *terminus post quem* for machine-

made tubing with shaped perforations, since beads with shaped perforations seem to occur in earlier archaeological contexts, perhaps as early as the late 19th century.

U.S. Patent No. 321,369 (June 30, 1885) to Wesley Jukes may represent a precursor of a process for manufacturing tubing with shaped perforations. Jukes claimed to have invented a method for manufacturing glass tubing by creating a molded ball of glass with a perforation produced by the insertion of a plunger into the glass while it was still in the mold. This hollow ball was then hand drawn to form tubing with walls of uniform thickness. He claims that prior to his invention, glass balls were marvered to create their shape, and as such, resulted in the production of balls (and their tubes) with walls of unequal thickness. Although he does not mention alternative shapes for either the mold or the plunger, it seems obvious that by changing their cross-sections, it would be possible to create tubing with shaped exteriors and perforations.

Prior to Jukes’s 1885 patent, glassworkers elsewhere in the world were aware of techniques for imparting exterior shapes to tubing by marvering. It is also likely that someone must have experimented with shaping perforations, but no evidence of such a process has yet been documented. Thus, Jukes’ patent presently serves as the basis for the hypothesis dating the initial production of tubing with shaped perforations.

By the end of the 1930s, there is clear evidence that tubing with shaped perforations was being manufactured using the Danner machine:

The blowpipe nose may be either a continuation of the refractory sleeve [i.e., circular] or a shaped tip of machined and polished nichrome steel. In the case of the refractory nose, if the extreme edge is irregular, due to “spalling” or mechanical abrasion, then very fine “flats” and ridges will be formed on the inside face of the tubing as it flows off the nose. These may be very minute, but being magnified by the tube wall give a bad appearance. For this reason the nichrome nose is usually employed... (Sibilia 1939:297).

There is relatively little historical evidence to determine the initial use of processes to create shaped perforations for beads. Nevertheless, based upon the above information it seems safe to hypothesize that the terminus post quem for drawn beads with shaped perforations appears to be the late 19th century.

Table 1. Patents for Shaped Tubing and Perforations.

Patentee	U.S. Patent No.	Patent Date	Foreign Patent	Applications
Arthur Houghton (Corning Glass Works)	586,188	July 13, 1897		Hand-operated mechanical process and apparatus to produce shaped tubing for thermometers with a circular perforation (Fig. 2)
August Raspillaire, Morgantown, West Virginia	834,165	October 23, 1906		Glass tubing with shaped exteriors, such as hexagonal and octagonal
August Raspillaire, Morgantown, West Virginia	839,421	December 25, 1906		Glass tubing with shaped perforations, such as hexagonal and octagonal
Richard Hirsch (Jena, Germany), Libbey Glass Co.	1,574,482	February 23, 1926		Shaped tubing with shaped perforations (Fig. 3)
Gaston Delpuch, Nemours, France	1,894,853	January 17, 1933	France March 28, 1930	Glass tubing and rods with shaped exteriors
James Gross	1,899,146	February 28, 1933		Hand-drawing method for shaped bars (tubing implied) for bathroom fixtures
William Said, Corning Glass Works	1,919,259	July 25, 1933		Mechanized vertical updrawing apparatus for shaped tubing with shaped perforations and colored stripes for thermometers
Ingvald Pedersen, Wilkinsburg, Pennsylvania	1,987,633	January 15, 1935		Glass tubing with polygonal exterior shapes
Georges Despret, Compagnies Reunies des Glaces et Verres Speciaux du Nord de la France	2,267,554	December 23, 1941	France November 19, 1938	Shaped instrument tubing

MECHANIZATION OF GLASS TUBING MANUFACTURE

For centuries and well into the 20th century, the manufacture of glass tubing and canes for the bead industry was a manual drawing process, but mechanization of the process began by the late 19th century (Bussolin 1847; Francis 1988; Kidd 1979; Springer 1921; Threlfall 1946). For canes and tubing:

The requisite amount of molten glass is gathered on an iron and marvered into the shape of a thick cylinder. On a punty or post with a flattened end is taken a small gather of glass, which is shaped into a suitable condition for the attachment of the parison, that is, into a flat disc.

The parison is meanwhile reheated at the furnace and, when soft, held vertically so that the end slowly

sinks, touches and adheres to the glass on the punty held directly beneath. When attachment is complete the two workmen engaged in the process, one holding the gathering iron, the other the punty, walk rapidly in opposite directions over a wooden track or runway, on which the glass rod, as it is drawn out, gradually comes to rest. The rate at which the men move decides the distance apart which they finally attain, and consequently the thickness of the rod produced. Cane so made needs no annealing, and when cool is cut up into suitable lengths. Uneven portions are rejected, whilst the rest is sorted according to diameter.

The only difference between the mode of making tubing and... rod is that the glass is gathered on a pipe and first worked into a thick-walled hollow cylinder (Hodkin and Cousen 1925:483).

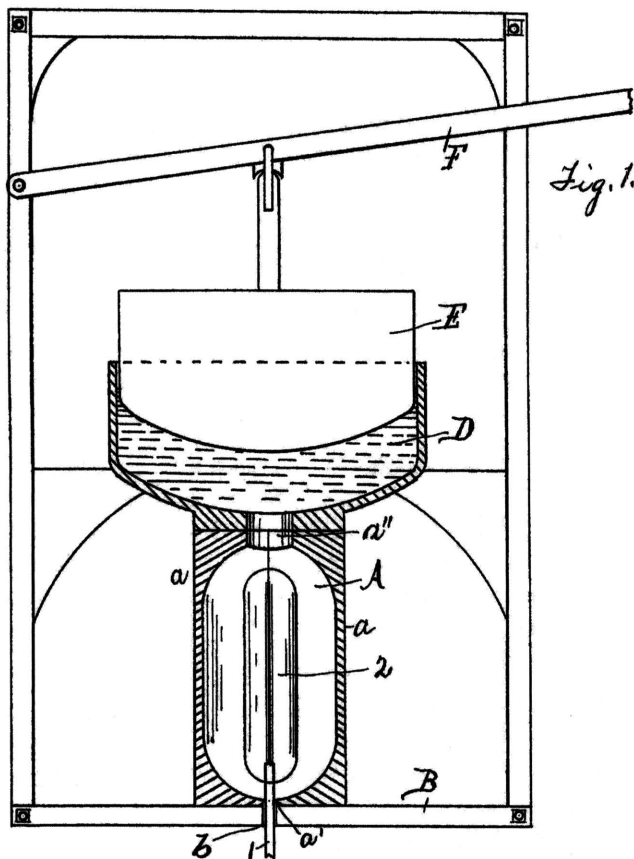

Figure 2. Hand-operated vertical downdrawing apparatus for the mechanical production of shaped tubing with circular perforations; Arthur Houghton (Corning Glass Works), U.S. Patent No. 586,188, July 13, 1897.

For beads, the preferred glass (vitreous silicate) was soda-lime (or lime) or alkali silicate (or alkali) glass for its relatively low melting point (generally 750° to 1000° C) and the readily available and inexpensive nature of its raw materials, basically:

- Silica from sand and crushed stone or sandstone
- Soda ash or saltwort, glasswort, barilla, salsola salt, sal soda, and glass salt (sodium carbonate)
- Saltcake (sodium sulphate)
- Crushed limestone (calcium carbonate)
- Quicklime (burnt limestone, calcium oxide), and/or
- Potash (potassium oxide), evaporated lye (leached wood ash), and pearl ash

These comprised the essential ingredients, but depending upon the quality, diaphaneity, color, and melting

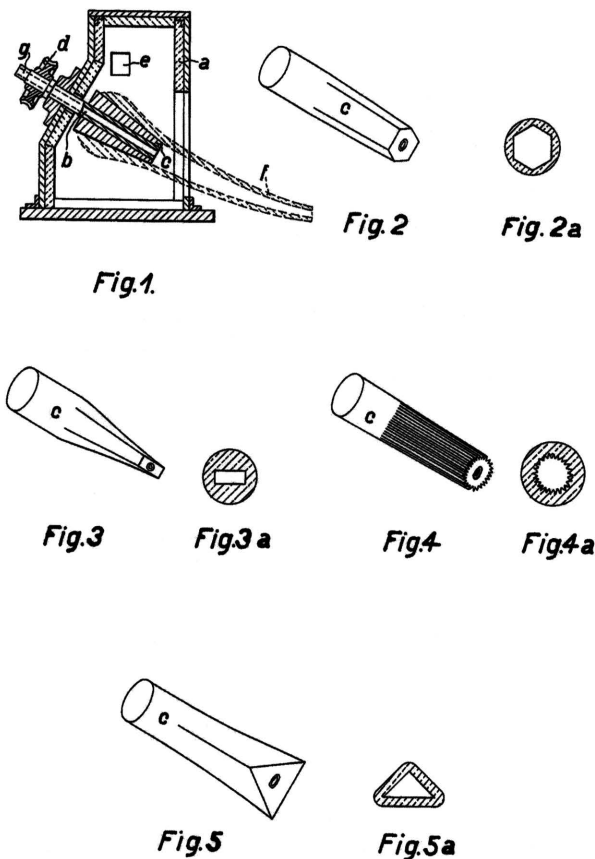

Figure 3. Shaped mandrels for a Danner tube-drawing apparatus; Richard Hirsch, Libbey Glass Co., U.S. Patent No. 1,574,482, February 23, 1926.

temperature desired for the tubing and canes, other substances were also added to the essential ingredients:

- Fluxes, to promote melting of the essential ingredients; e.g., borax, fluorspar (calcium fluoride), arsenic oxides, and antimony oxides
- Oxidizing agents, to promote decomposition of organic matter thus preventing discoloration of the glass and to prevent the reduction of ingredients desired in the glass; e.g., red lead or litharge (lead oxide), soda niter (sodium nitrate), and niter (potassium nitrate)
- Fining agents, to reduce the amount of small air bubbles (seeds) in glass; e.g., organic material plunged in the molten glass, ammonium nitrate, and the oxides of arsenic and antimony
- Reducing agents, to promote the incorporation of required oxides into the glass and to aid in the

formation of desired colors; e.g., coal or coke (carbon), Rochelle salt, and tin oxide

- Colorizing or decolorizing agents, to impart or eliminate color in glass (Brill 1999; Cable 1984; Hodkin and Cousen 1925:61-134; Phillips 1941:32-58; Weyl 1951); e.g.:
 - Clear, using glassmaker’s soap (manganese dioxide) and selenium, cobalt, or nickel oxides
 - White, using tin oxide
 - Black, using manganese (producing a transparent to translucent, very dark purplish red) and chromium with cobalt, copper, or ferric silicates
 - Red, using copper and selenium compounds, and Purple of Cassius (gold)
 - Amber, using iron, manganese, carbon, and sulphur
 - Yellow, using ferric or cerium silicates, uranium, chromium, or silver compounds, and cadmium sulphide
 - Green, using ferrous silicates, cupric oxide, and chromium
 - Blue, using cupric silicates and cobalt
 - Purple, using nickel oxide, manganese silicates, and cobalt.

Accompanying these naturally occurring and processed ingredients was a wide range of impurities, commonly oxides and silicates of iron (e.g., hematite, limonite, and magnetite), magnesium, and aluminum.

Every glassmaking concern had its own processes and secrets for producing glass, and similar properties and colors could be produced in many different ways depending upon the raw materials and procedures utilized. Also, after glass ingredients (frit) were melted and drawn into tubing and canes, the waste (cullet) from the pot, furnace, and factory floor was often recycled in subsequent batches. Glass with highly variable properties could be produced by tubing and cane makers, even though they used a similar procedure with each subsequent batch. With the advent of mechanized production of tubing and canes, it became essential that batches retained certain characteristics necessary for the proper operation of glassmaking apparatus. Hence, stricter controls were required for the mixing and melting of raw materials and their additives. Subsequently, the reuse of cullet declined and variabilities in the quality and color were reduced.

During the late 19th and early 20th centuries, four basic processes for the mechanized production of glass tubing were invented and refined:

1. *Vertical Updrawing*, initially patented in the United States by Roger Pease in 1891, and culminating with the

Woods (or Corning) process patented in the United States in 1931.

2. *Vertical Downdrawing* (or gravity feed), initially patented in the United States by Arthur Houghton in 1897, and culminating with the Vello process patented in France in 1929.

3. *Inclined Downdrawing* (or extrusion feed), initially patented in the United States by Edward Danner, Libbey Glass Co., in 1917.

4. *Horizontal Drawing*, initially patented in the United States by Robert Corl and Henry Hagemeyer for glass tubing.

At least one additional method was patented for the production of short tubes. Elihu Thomson (General Electric Co.) was issued U.S. Patent Nos. 761,111 (May 31, 1904) and 778,285 (December 27, 1904) for a method fusing granules of quartz coating a carbon rod with a high temperature electric arc or current.

The following discussion of the four principle techniques for mechanically drawing glass into tubes is confined to the production of tubes small enough to be used for beads. Documentation for the manufacture of larger cylinders of glass strictly for the production of window glass was identified, but has not been included.

Vertical Updrawing Processes

By the late 19th century, there were semi-mechanical processes patented in the United States for drawing molten glass into uniquely shaped tubing, specifically for the manufacture of thermometers. Mechanized vertical updrawing processes had been in wide use during the last half of the 19th century to produce large-diameter cylinders for the manufacture of window glass. In 1891, a mechanical vertical updrawing process for the “formation of cylinders, pipes, and other tubular or hollow bodies of glass” (United States Patent Office 1891:1) was patented by Roger Pease. This process was probably intended primarily for the production of window and sheet or plate glass, but could have been used for tubing of various sizes. Similar methods mentioning the manufacture of *tubing*, not just cylinders, were subsequently patented (Table 2).

The Raspillaire process explicitly allowed for the drawing of glass tubing with shaped exteriors. If the technique was used to produce tubes small enough for the manufacture of glass beads, then the canes could have been used for the production of multi-sided drawn beads (Karklins 1985: type I beads).

Table 2. Patents for Vertical Updrawing Processes and Apparatus.

Patentee	U.S. Patent No.	Patent Date	Foreign Patent	Applications
Roger Pease, Rose, Minnesota	463,644	November 24, 1891		Window glass cylinders, pipes, tubular or hollow articles
	463,645	November 24, 1891		
Alexander Humphrey, Fairmont, West Virginia	614,615	November 22, 1898		Glass cylinders or tubes
Phillip Ebeling, Findlay, Ohio	682,980	September 17, 1901		Window glass cylinders, hollow articles, pipes, and tubing
Roger Pease, Rose, Minnesota	788,142	April 25, 1905		Window-glass cylinders and hollow articles
	788,144	April 25, 1905		
August Raspillaire, Morgantown, West Virginia	804,173	November 7, 1905		Glass tubing
Joseph North, Lancaster, Ohio	810,218	January 16, 1906		Glass tubing and cylinders
August Raspillaire, Morgantown, West Virginia	834,165	October 23, 1906		Glass tubing with shaped exteriors, such as hexagonal and octagonal
August Raspillaire, Morgantown, West Virginia	839,421	December 25, 1906		Glass tubing with shaped perforations, such as hexagonal and octagonal
William Keyes, Alexandria, Indiana	935,663	October 5, 1909		Long glass tubing and cylinders
Stephan Forgo, New York	958,613	May 7, 1910		Glass rods and tubing
Edward Hanson, Kane, Pennsylvania	1,052,336	February 4, 1913		Glass tubing and cylinders
Benjamin Chamberlin, Corning Glass Works, Corning, New York	1,163,969	December 14, 1915		Medical and laboratory tubing (Fig. 4); adapted from a re-issued patent to A.A. Houghton dated November 22, 1908, Serial No. 11702
John Fagan, General Electric Co., Cleveland, Ohio	1,273,345	July 23, 1918		Glass rods and tubing (presumably for electrical applications)
	1,273,346	July 23, 1918		
James Smedley, General Electric Co., Cleveland, Ohio	1,278,046	September 3, 1918		Glass canes and tubing (presumably for electrical applications)
Frederick Keyes, Boston, Massachusetts	1,291,921	January 21, 1919		Glass tubing
Cleveland Quackenbush and James Smedley, General Electric Co., Cleveland, Ohio	1,325,265	December 16, 1919		Glass canes and tubing (presumably for electrical applications)
William Westbury, Okmulgee, Oklahoma	1,439,855	December 26, 1922		Glass canes

Table 2. Continued

Patentee	U.S. Patent No.	Patent Date	Foreign Patent	Applications
Louis Bruner and Simon Olsen, Brooklyn, New York	1,458,518	June 12, 1923		Glass tubing
Walter Riedel, Unter-Polaun, Bohemia, Czechoslovakia	1,545,349	July 7, 1925		Glass tubing
Schuller		1931	Germany	
William Woods, Corning Glass Works	1,829,429	October 27, 1931		Shaped and striped glass medical and laboratory tubing
Robert Salomon, Neuilly sur Seine, France	1,868,397	July 19, 1932	France October 11, 1927	Spun glass tubing and rods
Ingvald Pedersen, Wilkinsburg, Pennsylvania	1,892,806	January 3, 1933		Glass tubing
Robert Salomon, Neuilly sur Seine, France	1,894,201	January 10, 1933	France July 20, 1927	Glass tubing
Gaston Delpech, Nemours, France	1,894,853	January 17, 1933	France March 28, 1930	Glass tubing and rods with shaped exteriors
William Woods, Corning Glass Works	1,920,336	August 1, 1933		Glass instrument tubing
Ingvald Pedersen, Wilkinsburg, Pennsylvania	1,987,633	January 15, 1935		Glass tubing with polygonal sides
William Woods, Corning Glass Works	2,002,875	May 28, 1935		Multiple-bore glass tubing
William Woods, Corning Glass Works	2,141,456	December 27, 1938		Glass tubing with shaped exteriors and perforations for thermometers
Georges Despret, Compagnies Reunies des Glaces et Verres Speciaux du Nord de la France	2,267,554	December 23, 1941	France November 17, 1939	Shaped glass instrument tubing

The Woods (or Corning) process for creating tubing by the vertical updrawing method seems to have been the most successful of these techniques (Threlfall 1946:14). Nevertheless, these processes were typically employed for the production of window glass cylinders, medical instruments, and laboratory glassware.

Vertical Downdrawing Processes

Shortly after the initial vertical updrawing processes for the production of tubing appeared, vertical downdrawing processes came into being (Table 3).

It would seem inconceivable that Houghton's 1897 process would not have been mechanized shortly after its invention. It was not, however, until Chamberlin's 1915 patent for a vertical updrawing process that a motorized apparatus is documented for a glass factory, albeit for the manufacture of medical or laboratory tubing.

The downdrawing process is also referenced as the gravity feed process (Pincus 1983, 1:viii). Some time after its initial patent in 1929, the Vello process became the predominant and preferred process for the production of general commercial tubing, replacing the inclined downdrawing Danner process patented in 1917 (*see below*). The principal differences between the Vello and Danner

processes were that the Vello process resulted in the creation of glass with fewer air bubbles and that the molten glass flowed down a vertical metal blowpipe with a detachable tip of the appropriate size and shape of the finished tubing. Commercially, the Vello machine also was preferred because glass tubing could be drawn about twice as fast as with a Danner machine (Angus-Butterworth 1948:184; Bottger and Schotz 1994; Sibilia 1939:292).

Inclined Downdrawing Processes

It appears that the first major commercially viable invention for a mechanized process for general commercial tubing occurred in 1917, with patents in the United States by Edward Danner of the Libbey Glass Co. for a mechanized inclined downdrawing process and machine. It is also referenced as the extrusion feed or Danner process (Pincus 1983, 1:viii). The principal characteristic separating the Danner process from previous processes was that a molten stream of glass flowed down an inclined, rotating, conical blowpipe that had been coated with a shell of heat-resistant material such as fire clay. This blowpipe rotated at a speed from 4 to 10 revolutions per minute (Bailey 1930; Bottger and Schotz 1994; Sibillia 1939:297). The diameter of the tubing created by this process was determined principally, but not entirely, by the amount of air discharged through the blowpipe, the temperature of the glass at the point at which it leaves the blowpipe, and the speed by which the tubing was drawn away from the blowpipe. Solid canes of glass also could be produced by this method whereby the blowpipe was replaced with a solid conical mandrel. Danner consistently emphasized the terms "cylindrical" and "conical" for his descriptions of the blowpipes and mandrels in his patents. This and the 1926 patent by Richard Hirsch (*see above*) appears to support the view that during the early years when the Danner process was adopted, only tubing with circular perforations and exteriors was manufactured. After Danner patented his process and machine, numerous other individuals and companies patented improvements (Table 4).

By the mid 1930s, the new Vello process began replacing the Danner machine. The Danner machine retained one advantage, however, in that it could be used for the production of several very different glasses in succession (Sibilia 1939:292).

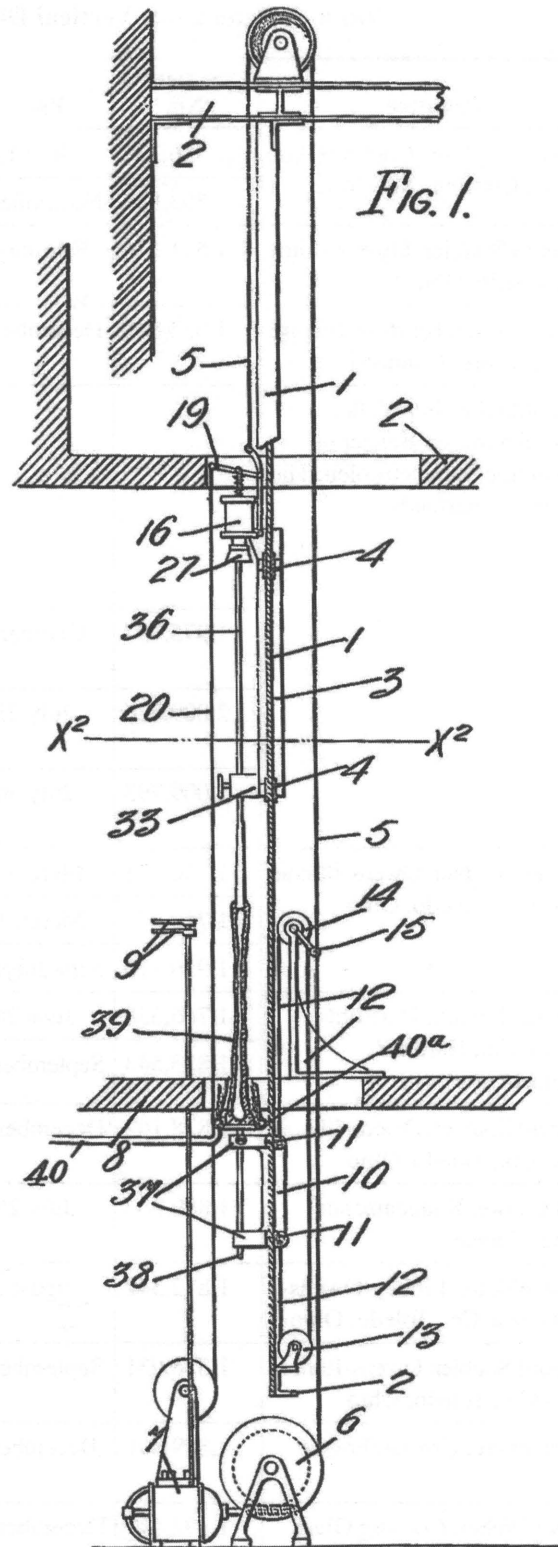

Figure 4. Vertical updrawing apparatus; Benjamin Chamberlin, Corning Glass Works, U.S. Patent No. 1,163,969, December 14, 1915 (adapted from a re-issued patent to A.A. Houghton, November 22, 1908).

Table 3. Patents for Vertical Downdrawing Processes and Apparatus.

Patentee	U.S. Patent No.	Patent Date	Foreign Patent	Applications
Arthur Houghton, Corning Glass Works, Corning, New York	586,188	July 13, 1897		Shaped glass tubing for thermometers
	593,581	November 16, 1897		
Leonard Soubier, Owens Bottle Co., Toledo, Ohio	1,571,216	February 2, 1926		Glass tubing
Sidney Grotta, Hartford-Empire Co., Hartford, Connecticut	1,653,848	December 27, 1927		Glass tubing
Leopoldo Sanchez-Vello, Maatschappij tot Beheer en Exploitatie Van Octroolen, The Hague, Netherlands			France June 8, 1929	Glass tubing
			British Patent No. 349,315, May 28, 1931 (Sanchez-Vello 1931)	
	1,975,737	October 2, 1934	France June 8, 1929	Glass canes and tubing (Fig. 5)
	2,009,326	July 23, 1935	France January 26, 1931	
2,009,793	July 30, 1935	France June 8, 1929		
Leonard Soubier, Owens-Illinois Glass Co., Toledo, Ohio	1,750,971	March 18, 1930		Glass tubing
	1,750,972	March 18, 1930		
	1,926,410	September 12, 1933		
George Howard, Hartford-Empire Co., Hartford, Connecticut	1,766,638	June 24, 1930		Glass tubing
	1,823,543	September 15, 1931		
Leonard Soubier, Owens-Illinois Glass Co., Toledo, Ohio	1,838,162	December 29, 1931		Glass tubing
Jean Cardot, Bagneaux sur Loing, France	1,869,303	July 26, 1932	France February 19, 1929	Glass canes and tubing
Allen Wilcox, Libbey-Owens-Ford Glass Co., Toledo, Ohio	1,872,542	August 16, 1932		Glass tubing
Leonard Soubier, Owens-Illinois Glass Co., Toledo, Ohio	1,876,031	September, 6, 1932		Glass tubing
Pierre Favre, Crosne, France	1,889,891	December 6, 1932	Austria November 6, 1929	Glass canes and tubing
Walter Weber, Corning Glass Works, Corning, New York	1,892,477	December 27, 1932		Glass tubing
Leonard Soubier, Owens-Illinois Glass Co., Toledo, Ohio	1,926,410	September 12, 1933		Glass tubing

Table 3. Continued

Patentee	U.S. Patent No.	Patent Date	Foreign Patent	Applications
Ernest Le Coultre	1,926,905	September 12, 1933	France May 22, 1930	Glass cane and tubing
Henry Richardson, Westinghouse Lamp Co.	1,933,341	October 31, 1933		Glass tubing
Jean Cardot, Corning Glass Works	1,949,037	February 27, 1934	France May 21, 1930	Glass tubing
Leopoldo Sanchez-Vello, Maatschappij tot Beheer en Exploitatie Van Octroolen, The Hague, Netherlands	1,975,737	October 2, 1934	France June 8, 1929	Glass tubing
	2,009,326	July 23, 1935		
	2,009,793	July 30, 1935		
David E. Gray, Corning Glass Works, Corning, New York	2,133,662	October 18, 1938		Glass tubing and cylinders
Walter Hänlein, Berlin-Spandau, Germany	2,155,131	April 18, 1939	Germany March 12, 1937	Quartz glass tubing
Edward Danner, Newark, Ohio	2,225,369	December 17, 1940		Glass tubing

Horizontal Drawing Process

Tubing had been produced for centuries by hand drawing out a hollow gather of glass horizontally. In 1896, Josef Riedel of Polaun obtained an Austrian patent (Privilegium Nr. 46/2423) for a horizontal drawing apparatus (Neuwirth 1994:107, Pl. 58):

Riedel received a privilege in 1896 for a “device to draw out molten glass into tubes and canes.” This device relieved the drawer of the work almost entirely, since he now only had to cover a relatively

short distance (5-8 meters), while the new device did the work of 60-70 meters (Neuwirth 1994:148).

This was not a completely mechanized apparatus, but rather a device to continue the drawing process initiated by the glassworker using the older hand-drawing process. From its patent illustration, the apparatus appears to be something like a conveyor belt possibly allowing the pontil or blowpipe to be placed on it so the drawing process could continue.

It appears that, at least in the United States, hand drawing was still a common method for producing small-diameter

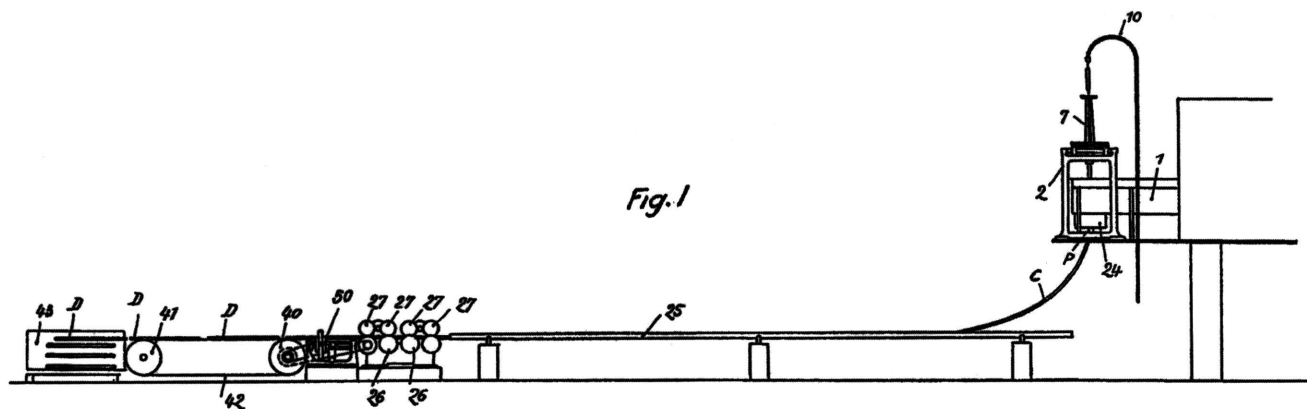

Figure 5. Vello downdrawing apparatus (edited version of patent drawing); Leopoldo Sanchez-Vello, British Patent No. 349,315, May 28, 1931 (process patented as early as June 8, 1929, in France).

Table 4. Patents for Inclined Downdrawing Processes and Apparatus.

Patentee	U.S. Patent No.	Patent Date	Foreign Patent	Applications
Edward Danner, Libbey Glass Co., Toledo, Ohio	1,218,598	March 6, 1917		Glass canes and tubing (Figs. 6-7)
	1,219,709	March 20, 1917		
Albert Wilcox, Bridgeport, Ohio	1,550,995	August 25, 1925		Glass canes and tubing
Richard Hirsch, Jena, Germany, Libbey Glass Co., Toledo, Ohio	1,574,482	February 23, 1926		Glass tubing with shaped exteriors and perforations
Pancras Schoonenberg, Eindhoven, Netherlands, Naamlouze Vennootschap Philips' Gloeilampenfabrieken	1,637,458	August 2, 1927	Netherlands December 2, 1920	Glass canes and tubing
	1,642,312	September 13, 1927	Netherlands August 20, 1926	
Karl Peiler, Hartford-Empire Co., West Hartford, Connecticut	1,663,093	March 20, 1928		Glass canes and tubing
	1,857,257	May 10, 1932		Glass tubing
	1,857,791	May 10, 1932		Glass tubing
James Bailey, Corning Glass Works, Corning, New York	1,892,126	December 27, 1932		Glass tubing
Jules Arrault, Chalon-sur-Saone, France	1,941,924	January 2, 1934	France November 16, 1928	Glass tubing with a uniform diameter
Leonard Soubier, Owens-Illinois Glass Co., Toledo, Ohio	1,977,956	October 23, 1934		Glass canes and tubing

tubing a decade prior to the invention of Danner's process. (September 10, 1907) to Cornelius Nolan, Libbey Glass Co, for a tube-forming apparatus that allowed a glassblower
This is noted in part because of U.S. Patent No. 865,517

Table 5. Patents for Horizontal Drawing Processes and Apparatus.

Patentee	U.S. Patent No.	Patent Date	Foreign Patent	Applications
Robert Mackey Corl and Henry F. Hagemeyer, Toledo, Ohio	1,298,463	March 25, 1919		Glass tubing
Louis Bonnet, Perpignan, France	1,466,575	August 28, 1923		Glass tubing on a wire
James Gross, Brooklyn, New York	1,899,146	February 28, 1933		Glass tubing with unique cross-sections and stripes
Joseph De Silva, Corning Glass Works	1,920,366	August 1, 1933		Glass tubing for thermometers
William J. Woods, Corning, New York	2,002,875	May 28, 1935		Glass tubing
	2,085,245	June 29, 1935		
Randolph H. Barnard, Toledo, Ohio	2,150,017	March 7, 1939		Glass tubing with various cross-sectional shapes

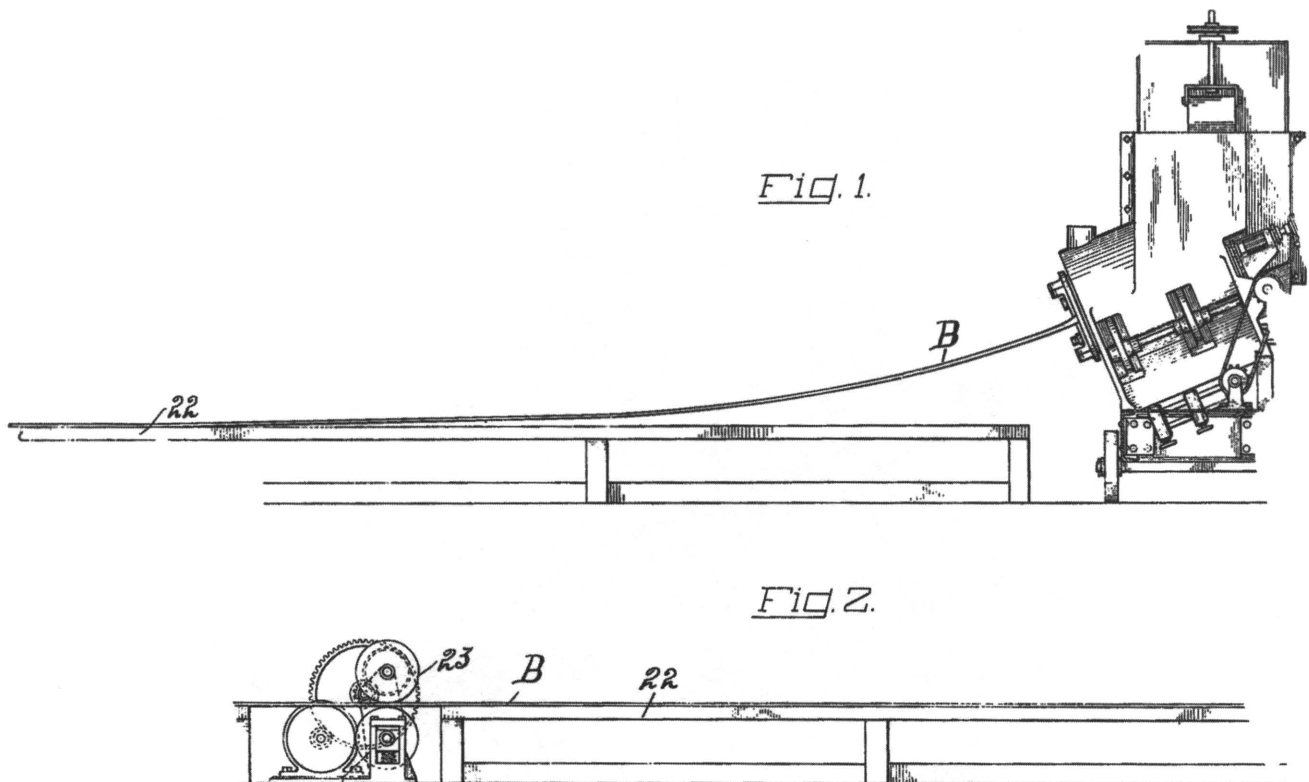

Figure 6. Danner inclined downdrawing apparatus (edited version of patent drawing); Edward Danner, Libbey Glass Co., U.S. Patent No. 1,218,598, March 6, 1917.

to hand draw tubing while supporting his blowpipe on a wheeled platform that he pulled as he walked backwards.

Similarly, at the French beadmaking factory of Alfredo Salvadori, established in 1929, hand drawing continued well past World War II:

Until the 1950s, the process of drawing out the gather was done by hand. Now [presumably the 1980s], a machine replaces the two men who ran in opposite directions, each holding one end of the metal rod to which the hollow glass gather was attached. A regulating mechanism sets the speed; the faster it moves, the thinner the tube. Despite this mechanization, Gérard Salvadori remains one of the few masters at drawing canes by hand (Oppen and Oppen 1991:51).

Various patents for mechanically drawing horizontal glass tubing were granted after Danner's inclined downdrawing process was patented (Table 5).

Commercially Viable Tube-Drawing Processes

Of all the newer processes that appeared after the invention of the Danner inclined downdrawing process, it

appears that the only ones that enjoyed widespread usage were the Vello vertical downdrawing process patented in 1929 and the Woods (or Corning) vertical updrawing process patented in 1931. The Vello process replaced the Danner process for the production of general commercial tubing and canes because it could produce tubing at a rate nearly double that of the Danner process, while the Woods process seems to have been used principally for the production of medical and laboratory tubing (Angus-Butterworth 1948:184; Threlfall 1946:14; Wilson 1984).

Which of the above processes were initially used to produce glass tubing for the manufacture of beads has yet to be determined. Nevertheless, based on widespread use of these techniques for other small-diameter tubular products, it is hypothesized that the terminus post quem for the mechanized production of drawn glass tubing used in the manufacture of beads appears to be the late 19th century.

DISTINGUISHING HAND- AND MACHINE-DRAWN BEADS

Distinguishing hand- vs. machine-drawn beads is difficult at best. Since machine-drawn tubing could be

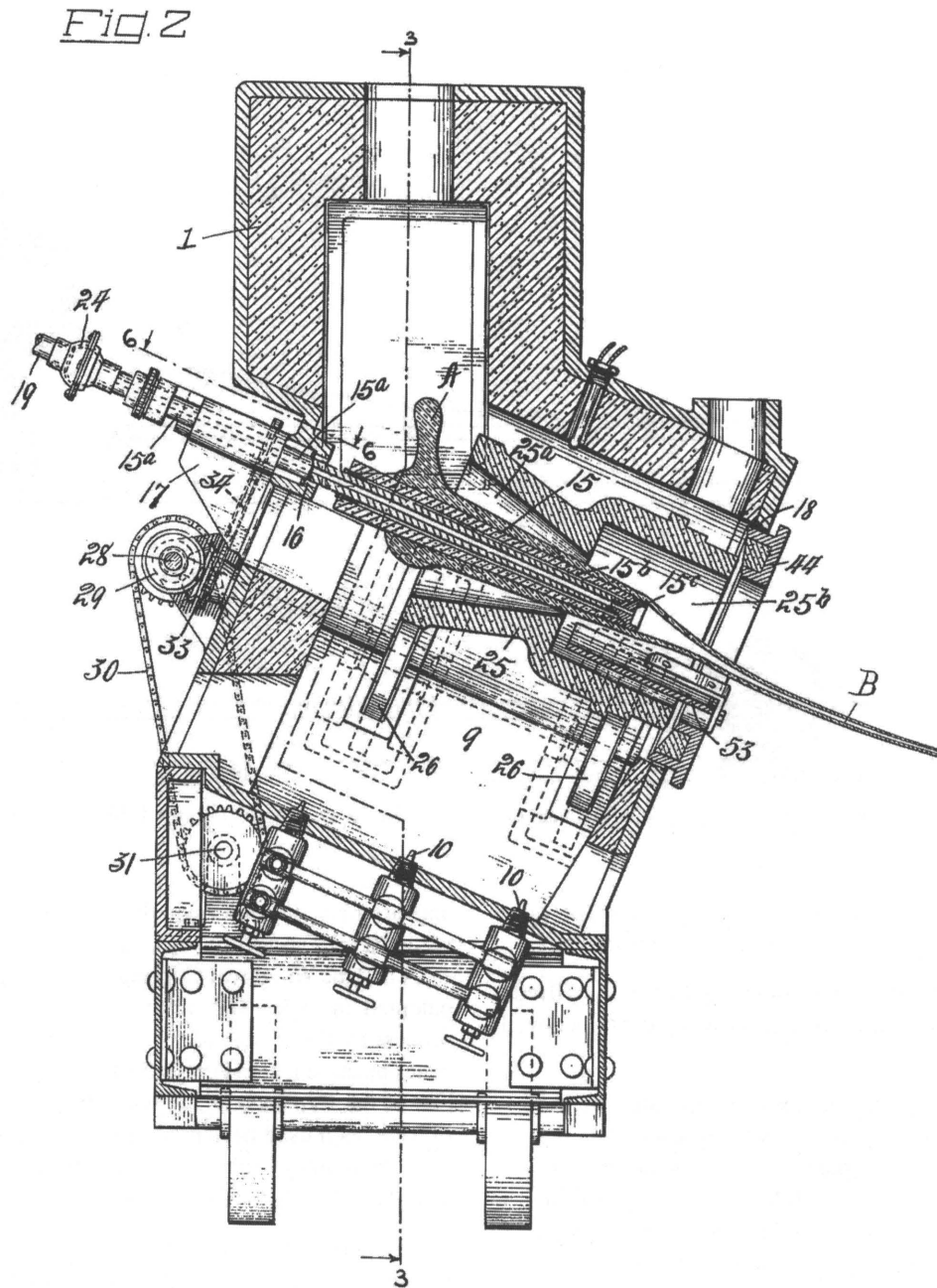

Figure 7. Close-up view of the Danner inclined downdrawing apparatus; Edward Danner, Libbey Glass Co., U.S. Patent No. 1,218,598, March 6, 1917.

produced with dimensions regulated by mechanical means, it would seem probable that resultant beads would have very uniform shapes and walls with uniform thicknesses. Well made hand-drawn tubing also could produce similar appearances, however. If we are to believe Richard Threlfall (1946:14), distinguishing hand-drawn from machine-drawn tubing should not be too difficult:

If you are ever in doubt whether a piece of tubing or rod is machine- or hand-drawn, look at the striae. If these run parallel to the long axis, the glass is hand-drawn, for most machine-drawing gives the glass a twist which is never taken out and therefore the striae in it run off at an angle greater or less according to the diameter of the glass.

Observing parallel vs. angled striations within small beads may be impossible without access to a high-magnification microscope, although for elongated beads, such as bugles, the striations may be visible to the naked eye. The determination of hand- vs. machine-drawn beads may also utilize attributes such as decoration, uniform shape, relative sharpness of edges, bead size, and perforation size and shape.

With the mechanization of the manufacture of glass tubing, dimensional tolerances could be more tightly controlled. Within an assemblage of beads from an archaeological context, these tighter tolerances may be discernable within a relatively large population of beads comprising a single variety and/or size. Tolerances for wall thickness, perforation diameter, and bead size and shape may be less than those for beads produced from hand-drawn tubing. Comparisons of the dimensions of beads from pre-industrial vs. industrial-era contexts may provide better insights into tolerance variations. Presently, however, there is very little reliable data that can be used to positively distinguish hand- vs. machine-drawn beads using such attributes. For now, the best indicator may be perforation shape.

Beads with shaped (e.g., square) perforations manufactured by mechanized processes exhibit straight walls and sharp edges. Earlier beads with shaped perforations created by hand-drawn techniques appear to have poorly shaped walls and somewhat rounded edges. Machine-made beads with shaped perforations also may have coatings, such as enameling or metallic coatings, on the walls of the perforation.

Until additional historical documentation becomes available, the age and distinguishing characteristics of machine-made beads will be more a matter of conjecture than of fact. It is hoped that such documentation will appear more frequently as the history of the late 19th and 20th centuries becomes more relevant to archaeological investigations.

MACHINE-MADE BEADS

During the 19th century, there were numerous methods for the manufacture of machine-made mold-pressed beads (Ross 2006:43-45). By the early 19th century, mold-pressed beads were manufactured using hand-operated mechanical molding machines; e.g., U.S. Patent No. 79,635 (July 7, 1868) to George J. Capewell, West Cheshire, Connecticut, for an improved glass-pressing machine to make glass beads and other glass ornaments. Other than hand-operated tongs, such hand-operated machines may have been in use

earlier in Bohemia, the presumed origin for this type of manufacture, but no patents for such devices earlier than 1868 have yet been identified. The earliest known machine-operated method for the manufacture of mold-pressed beads may have been the "apparatus for molding fancy articles in glass, crystal, &c.," first patented by Charles Gaston Picard, Paris (French patent dated December 22, 1881; U.S. Patent No. 259,203 dated June 6, 1882). In Bohemia, the earliest documented patent is the button and bead press of 1888, by Albrecht Max, Reichenberg, Austria (Austrian Privilege No. 38/1616). The earliest American machine was one patented on March 21, 1893 (U.S. Patent No. 493,808) by William Bechtold of New York.

It remains unknown when the first machine-made beads were manufactured from glass tubing. In 1877, a machine for the cutting of beads from glass tubing was patented in Austria (Austrian Privilege No. 27/112) by Adolf Schindler, Vienna (Neuwirth 1994:138). Glass tubing small enough for beadmaking may have been manufactured as early as the late 19th century using Pease's vertical updrawing process, but there is no record yet identified that indicates beads were manufactured from such tubing.

According to Peter Francis, Jr. (1988:7), Danner machines were used for the production of bead tubing in Venice from perhaps the 1920s. Francis, on his web site for the Center for Bead Research, also stated that Danner machines were used for bead tubing in Venice and Bohemia shortly after the invention of the process in 1917. Unfortunately, Waltraud Neuwirth (1994) made no mention of the use of any mechanized process for the production of bead tubing in Bohemia. The only machines noted for drawn beads were cutting machines such as the one mentioned previously.

U.S. Patent No. 1,493,044 (May 6, 1924) to Gustave A. Lexman of New York was for a machine for making glass articles. In the patent it is stated that "this invention relates to a machine for making glass articles such as beads, buttons, and the like, from canes, rods or sticks of glass." The process required six solid glass canes which were held vertically. Their ends were heated, these were pressed in a mold to form beads, and the perforation was made by a sliding pin. This description appears to describe the manufacture of mold-pressed beads using solid rods of glass. Lexman, however, distinguishes canes and rods, but from his description it appears that both terms refer to solid rods of glass, not glass tubes.

U.S. Patent No. 1,580,076 (April 6, 1926) by Jean Paiseau, Courbevoie, France, was for the machine manufacture of glass beads using his process for the machine manufacture of horizontal glass tubes patented earlier on August 28, 1923 (U.S. Patent No. 1,466,575; *see above*).

It appears that totally machine-made drawn glass beads may not have been manufactured prior to the 1917 invention of the Danner process. Machines for the cutting of glass tubing for beads were in existence at least by the mid-19th century. It is therefore hypothesized that the terminus post quem for machine-manufactured drawn glass beads appears to be post-1917.

CONCLUSION

The research presented in this article has been confined temporally to the period prior to World War II. It has focused on the machine production of drawn glass beads. Machine manufacturing of mold-pressed beads and some processes for the mechanization of wound glass bead production did exist prior to the early 1940s (e.g., U.S. Patent No. 1,391,527 on September 20, 1921, to William F. Chase, Peekskill, New York, for a hand-operated machine to manufacture wound glass beads on a wire). It is highly probable that other mechanized techniques were used during the period. By documenting the earliest techniques yet known and hypothesizing *termini post quem* for specific processes, it is hoped that additional historical and archaeological research will expand our knowledge and establish temporal markers for future use.

REFERENCES CITED

Angus-Butterworth, Lionel Milner

1948 *The Manufacture of Glass*. Pitman, New York.

Anonymous

1881 The Glass-Bead Industry of Venice (translated from a German article in *Die Gartenlaube*, date unknown). *American Pottery & Glassware Reporter*, Thursday, January 27, 1881.

Bailey, James

1930 Danner Process of Glass Industry. *Glass Industry*, August. Reprinted in Pincus (1983) 1:212-213.

Bottger, M. and E. Schotz

1994 Platinum Feeders in the Danner or Vello Process. *Glass Machinery Plants and Accessories* 7(5):61-62.

Brill, Robert H.

1999 *Chemical Analyses of Early Glasses*. 2 vols. Corning Museum of Glass, Corning.

Bussolin, Dominique

1847 *Les célèbres verreries de Venise et de Murano. Description historique, technologique et statistique de cette industrie divisée dans ses diverses branches, avec des notices sur le commerce en général des émaux et des conteries*. H.F. Münster, Venice (see Karklins with Adams 1990 for an English translation of the beadmaking sections).

Cable, Michael

1984 Principles of Glass Melting. In *Glass: Science and Technology*, edited by D.R. Uhlmann and N. J. Kreidl, vol. 2, pp. 1-44. Academic Press, New York.

Carroll, B. Harvey, Jr.

1917 Bead Making at Murano and Venice. Unpublished manuscript. General Records of the Department of State (RG-59), State Decimal File 1910-1929, File No. 165.184/3. National Archives, Washington. Reprinted as "Bead Making at Murano and Venice, Parts 1 & 2," *The Glass Industry* 3(11):224-227, November 1922; 3(12):248-250, December 1922. Also in *Beads: Journal of the Society of Bead Researchers* 16:17-37 (2004).

Francis, Peter, Jr.

1988 The Glass Trade Beads of Europe: Their Manufacture, their History, and their Identification. *World of Beads Monograph Series* 8. Center for Bead Research, Lake Placid, New York.

Hodkin, Fredrick William and Arnold Cousen

1925 *A Textbook of Glass Technology*. D. Van Nostrand, New York.

Hoffman, J.J. and Lester A. Ross

1974 *Fort Vancouver Excavations - VIII, Fur Store*. Unpublished manuscript. National Park Service, Fort Vancouver National Historic Site, Vancouver, Washington.

Karklins, Karlis

1985 Guide to the Description and Classification of Glass Beads. In *Glass Beads*, 2nd edition, pp. 85-118. Parks Canada, Studies in Archaeology, Architecture and History. Ottawa.

Karklins, Karlis with Carol F. Adams

1990 Dominique Bussolin on the Glass-Bead Industry of Murano and Venice (1847). *Beads: Journal of the Society of Bead Researchers* 2:69-84.

Karklins, Karlis and Gary F. Adams

n.d. Beads from the Hudson's Bay Company's Principal Depot, York Factory. Manuscript in preparation. Parks Canada, Material Culture Research Centre, Ottawa

Kidd, Kenneth E.

1979 Glass Bead-Making from the Middle Ages to the Early 19th Century. *History and Archaeology* 30. Parks Canada, Ottawa.

Neuwirth, Waltraud

1994 *Perlen aus Gablonz: Historismus, Jugendstil/Beads from Gablonz: Historicism, Art Nouveau*. Privately published, Vienna.

Opper, Marie-José and Howard Opper

1991 French Beadmaking: An Historical Perspective Emphasizing the 19th and 20th Centuries. *Beads: Journal of the Society of Bead Researchers* 3:47-59.

Phillips, Charles John

1941 *Glass, the Miracle Maker: Its History, Technology, Manufacture and Applications*. 2nd ed. Pitman, New York.

Pincus, Alexis G.

1983 *Forming in the Glass Industry*. 2 vols. Ashlee, New York.

Ross, Lester A.

1999 *Glass and Ceramic Trade Beads from Archaeological Excavations Conducted in 1986, 1987, and 1988 at American Fur Company (1828-1865), Northwest Fur Company (1865-1867), and U.S. Army (1864-1867) Fort Union (32-WI-17), North Dakota*. Unpublished manuscript. National Park Service, Midwest Archeological Center, Lincoln, Nebraska.

2004 Glass and Ceramic Beads from the Shepherd Ranch Site (CA-INY-4673-H), Manzanar National Historic Site, Inyo County, California, 1864-1905. Unpublished manuscript. National Park Service, Western Archeological and Conservation Center, Tucson, Arizona.

2006 Bohemian Faceted-Spheroidal Mold-Pressed Glass Bead Attributes: Hypothesized *Terminus Post Quem* Dates for the 19th Century. *Beads: Journal of the Society of Bead Researchers* 15:41-52.

Sanchez-Vello, Leopoldo

1931 Method of Making Glass Tubing [British Patent No. 349,315]. *Journal of the Society of Glass Technology* 15:429-430, Abstract 902.

Sibilia, Victor E.

1939 The Automatic Production of Glass Tubing and Rod on the Danner Machine. *Journal of the Society of Glass Technology* 23:292-307.

Sprague, Roderick

1985 Glass Trade Beads: A Progress Report. *Historical Archaeology* 19(2):87-105.

Springer, J.F.

1921 Machine Drawing of Glass Tubing. *Glass Industry*, May-June. Reprinted in Pincus (1983) 1:198-203.

Threlfall, Richard E.

1946 *Glass Tubing*. British Association of Chemists, London.

United States Patent Office

1891 *Manufacture of Glass Cylinders, Pipes, &c.* Patent No. 463645, issued on November 24, 1891, to Roger S. Pease, Rose, Minnesota.

Weyl, Woldemar A.

1951 *Coloured Glasses*. Society of Glass Technology, Sheffield.

Wien [Vienna], Lloyd

1845 Bericht über die gegenwärtige österreichische allgemeine Industrie-Ausstellung. *Beilage zum Journale des österreichischen Lloyd*. Redigirt von Ernst von Schwarzer, Wien. Freitag am 6. Juni 1845, Nr. IX; Sonntag, am 8. Juni 1845, Nr. X sowie Dienstag am 10. Juni 1845, Nr. XI. [Report of those present at the Austrian General Industry Exhibition. *Supplement to the Journals of the Austrian Lloyd*, No. 9, June 6, 1845; No. 10, June 8, 1845, and No. 11, June 10, 1845; edited by Ernst von Schwarzer.]

Wilson, R. W.

1984 Tubing and Rod Manufacture. In *Glass: Science and Technology*, edited by D. R. Uhlmann and N. J. Kreidl, vol. 2, pp.137-147. Academic Press, New York.

Lester A. Ross
2667 Garfield Street
Eugene, OR 97405
Email: larincwebsite@comcast.net